

THE GENOGRAM

Training by Sandrine Charlet, ASMAE, for the team of the Early Childhood Development Centre
Inter Aide, Antananarivo, 2005

Sandrine Charlet – ASMAE 2005

English translation Enfants & Développement 2014, edited Anne Carpentier, Pratiques

Foreword:

Learning how to use a genogram is more effective by actually doing a genogram rather than through a theoretical presentation. The following information is intended to explain how to do a genogram and to provide different contexts for the use of this tool. Role-playing should be practised afterward so social workers can better understand the usefulness of the tool.

Definition:

The genogram is a graphic and symbolic representation of a family, generally comprising at least three generations (children, parents and grandparents).

It can include the following pieces of information:

- The structure of the family (number of children, marriages, separations and re-marriages, dates of births and deaths, gaps of time between the births...);
- Family history (important life events such as illnesses, separations, marriages, divorces, relocations, job losses, births, miscarriages, abortions, deaths...);
- Socio-economic elements relevant to members of the family (professions, upward social mobility, bankruptcies, socio-economic level...);
- Relationships between family members (love, jealousies, conflicts, close bonds, violence, choice of nicknames...);
- The health of the family, including psychological health (illnesses, psychiatric disorders if any personal characteristics including positive traits as well as failings...).

The genogram is a tool allowing social workers/family counsellors to better know the family they are working with. It helps to distinguish family members between one another. It offers the possibility to the family and the social worker/family counsellor to establish benchmarks, find links and give meaning to interactions that were not previously understood. It is preferable to create the genogram with the family if possible, in one or more sessions, with the participation of the family members.

We can use the genogram after the first encounters either with a free or more structured style: either it is built slowly, step by step during the interviews ('freestyle' method), or we use this as the basis for the meeting and its construction becomes the objective of discussions with family (structured manner). In each case, it is always a tool to help synthesize a family situation and allows the social worker (SW) to enter into the family history and relational patterns.

The genogram serves as a guide to meet and learn about the family: it helps asking about the familial structure, family history and relationships between members. It gives access to beliefs, traditions, family values and reference points. It helps the user to understand in what context each family member evolves. It helps create links between the stories of each family member and helps the SW to spot any relevant coincidence (same birthdates, or for example the birth of a child taking place on the same date as a grandparent's death).

All the information given by the family during the making of the genogram can be used directly or expanded on during future meetings. Most often, the act of drawing the genogram generates curiosity and can generate a atmosphere of quiet and concentration. Indeed, people take interest in the drawing and respond more calmly to the questions asked while observing what is noted and the manner in which the genogram is drawn. Moreover, the drawing is accessible to all, even those who may be illiterate.

The genogram gives families the opportunity to talk about difficult or personal matters. When these kinds of information are shared, we should listen and not be afraid to learn more: if the family members share about intense life experiences, it means they feel ready for someone to hear about them. If we behave as if we're upset or if we do not show interest in exploring the subject, we send the family the message that the subject is taboo and that there is shame in sharing it.

Issues with the genogram

The genogram is a tool allowing the social worker/family counsellor and the family to offer hypotheses about links with their familial history, their relationships and difficult experiences they've endured. These hypotheses should always be contrasted with the family's reality, and not treated as definitive truths. They are nothing more than suppositions which can be made from observing the story related by the family.

All of the information taken from the genogram is influenced by the subjectivity of the people creating it: namely the family and the SW. Indeed, the family may involuntarily omit important details of their history or mix facts when they touch on subjects of concern. Conversely, the SW may not hear certain important facts. The genogram gives the impression of a transcript of "reality", but it is only one perspective of that reality.

Lastly, the genogram is a temporary "snapshot" of the family dynamics. Structural information (such as dates of births, marriages and divorces) remain constant timewise whereas family relationships are constantly evolving — generating additional well-being, or to the contrary, suffering. It is important not to freeze the family in the genogram but on the contrary, to revisit it as often as needed.

A variant: the imaginary genogram

This genogram is used after the creation of a biological genogram, when trust with the person or the family has been established and the family history is known and has been worked on. The imaginary genogram does not represent the biological family but allows people who draw it to create a family they would like to belong to.

Administering of the imaginary genogram takes place over two phases:

1. First ask the person, couple or family to find 10 people who they consider the most important in their life, or that of the couple or the family. These people can be alive

or deceased, they can be loved or detested, they can be family members or not (friends, co-workers...)

- We then seek to gather the 10 chosen people in the form of a genogram, as if they were a real family. We make it clear that the objective is to place each of these 10 people in the spot which suits them best: each can be found in a place that may not be what they have in reality. It is important that each is placed with a parental link, even those with whom there is no family link: they can be called "foster parents" or "godfather, godmother".

The imaginary genogram makes the person's capacity for resilience become apparent. The imaginary family offers an alternative vision to the determinism of the biological genogram. It shows the relationships on which a person has been able to rely over the course of his/her life when facing difficult situations. They give value to reparative attachment relationships outside of the family that have helped them to become the person they are now.

The imaginary genogram offers the same limitations as the biological genogram: it is not based on reality but is linked to the subjectivity of the persons drawing it; therefore, the hypotheses generated allow the SW to examine suppositions rather than verified truths.

Some useful symbols

Men:



Woman:



Deceased person:



Alcoholism:



Live-in partner:

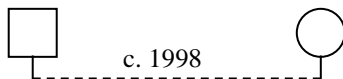

Marriage:

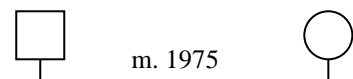

Break-up:

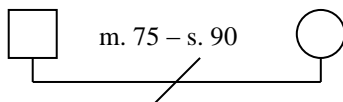

Divorce:

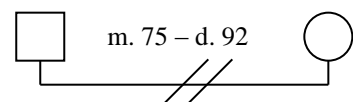

Marriage with children:

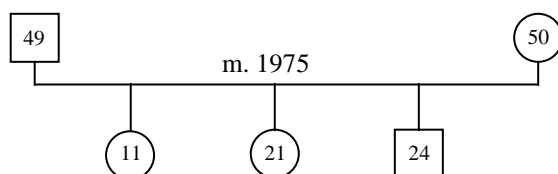

Over several generations:

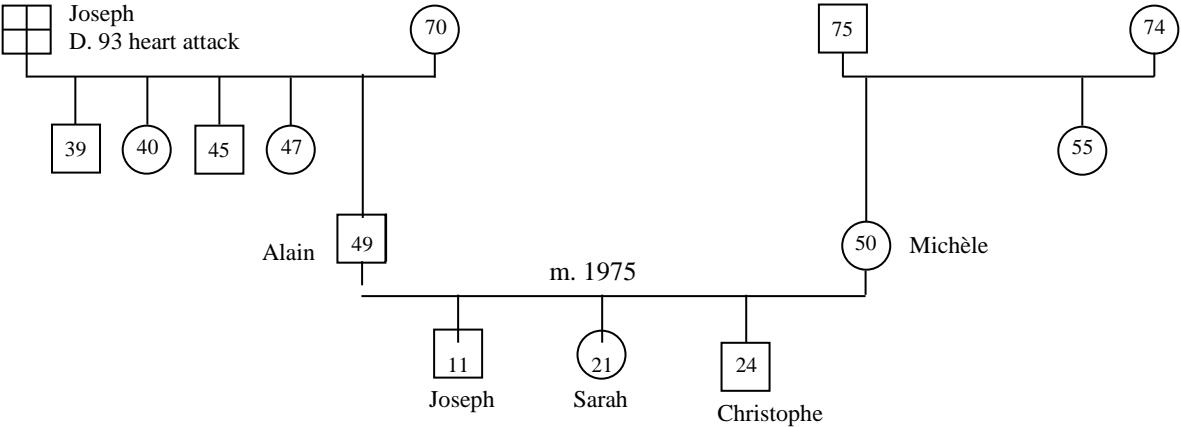

Marriages, divorces et family restructuring:

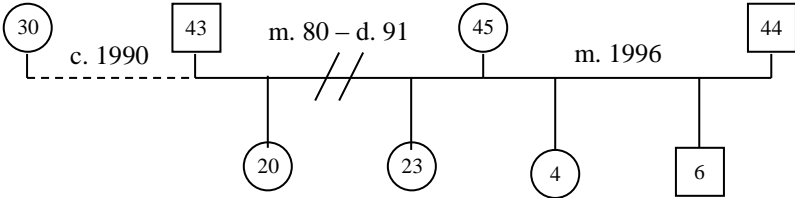

Pregnancy:

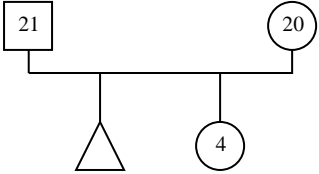

Abortion:

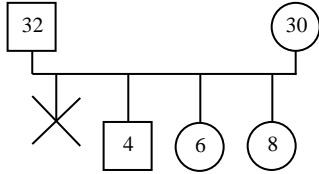

Still-birth / miscarriage:

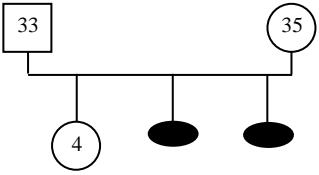

Adoption:

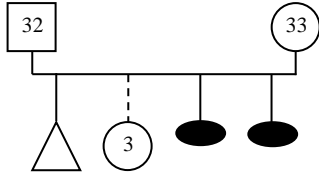

Fraternal twins:

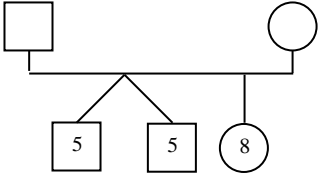

The actual relationships

Proximity, close relationship:

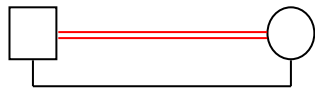

Conflicts, quarrels :

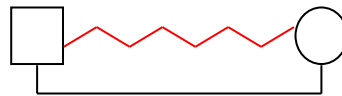

Intensely close relationship, strong connection:

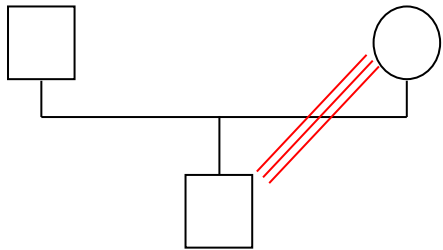

Distant, cold relationship:



Intense relation with conflict:

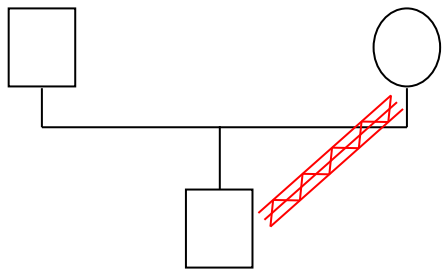

Break-up:

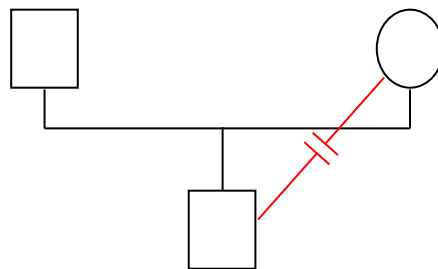

Domination / submission :

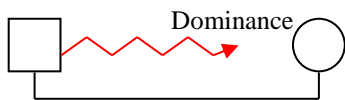

Violence :

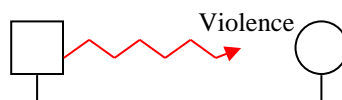

Example of relationships :

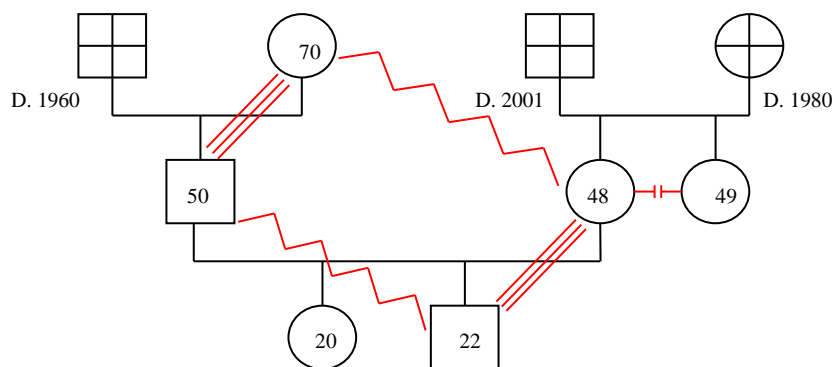

People living in the same house:

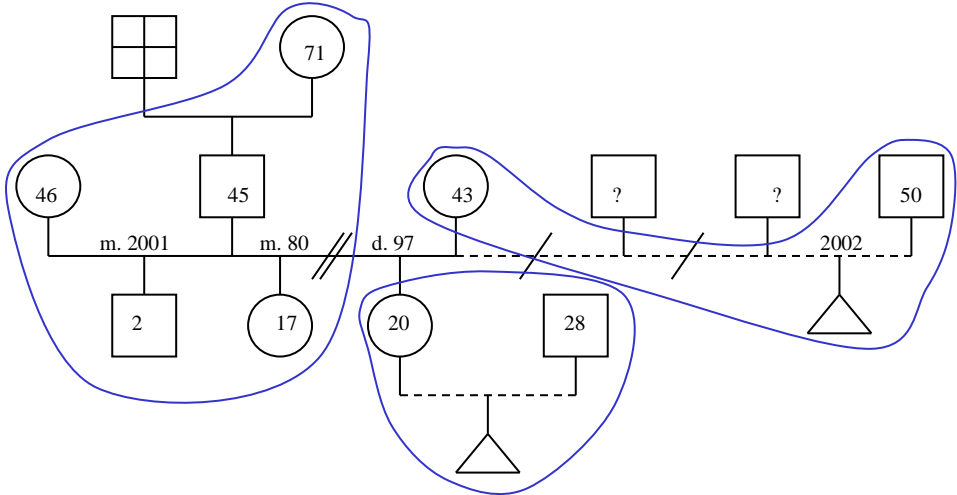

Use the symbols shown above when drawing your genograms, so that everybody can understand them. If you need additional symbols: do not hesitate to invent your own! Also include on the genogram all important events and details that you consider meaningful.

Example of a genogram

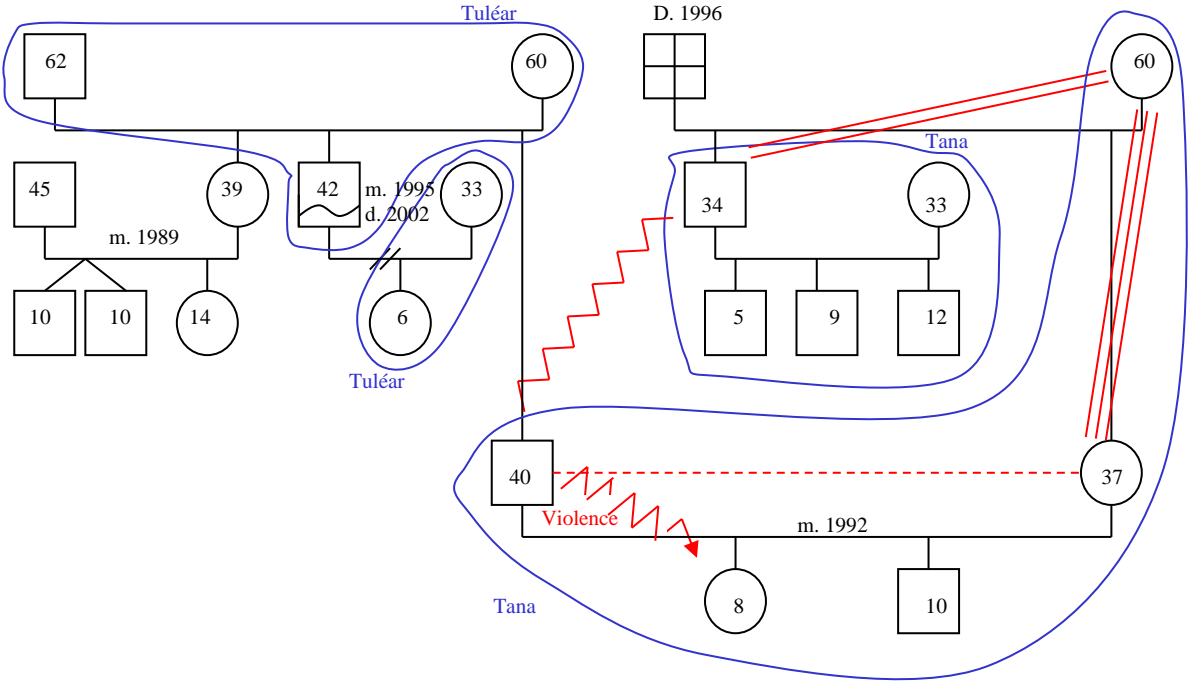

THE GENOGRAM

Asmae, Antananarivo, Madagascar – November 2005

1. Definition

The genogram is like a family tree, a framework which represents a family over at least three generations (children, parents and grandparents). We use standardized symbols to represent different things (g. such as male and female symbols).

Through this framework, we can obtain the following information:

- The structure of the family and its history (number of children, marriages, remarriages, divorces, dates of births and deaths, relocations, loss of employment, miscarriages, abortions, loss of work, alcoholism ...)
- Relationships between family members (close relationships, strong connections, conflicts, violence...).

Exercise applying symbols with the family (4 groups).

Corrections of the genogram for each group.

Exchanging genograms between groups and reading them.

2. What is the purpose?

The genogram enables us:

- To discover the world of the family.
- To better understand the family's beliefs and values.
- To understand the family more quickly, and clarify their family history. Often, the genogram allows the family to give a sense of its history and to better understand interactions within the family.
- To ask questions we may not have been able to without this tool. For example: The structure of the family, the family history, and the relationships that link family members.
- The family is given a chance to discuss matters that are often difficult or personal. When this is the case, we should listen and not be afraid to go further: if the family reveals a difficult situation, this means they are ready to be listened to. If we show discomfort or we avoid taking the subject further, this shows the person that they should not talk, that it's taboo. It can also reinforce beliefs that the subject is shameful.

- To formulate hypotheses. A hypothesis is a supposition to try to understand the experiences of the family or of an individual. It's a working tool. The hypothesis is not the truth! A hypothesis serves to guide the work with the family or the individual. The hypothesis orients our questions and our research for additional information. It helps to guide our actions. If the hypothesis is not confirmed, it should be abandoned.

Example: A mother who is not doing the necessary steps to obtain the birth certificate for one of her children. What sort of questions could you ask and what kind of hypotheses could you formulate? And what sort of actions would you undertake?

1	2	3	4	5
IDENTIFICATION OF PROBLEM	FORMULATION OF HYPOTHESES	VERIFICATION OF THE HYPOTHESIS	ACTION TO TAKE	EVALUATION
<i>A mother who is not taking the necessary steps to obtain the birth certificate of one of her children.</i>	a) Perhaps there's a financial reason b) Maybe she's afraid to go to the city hall, has no self-confidence c) Maybe it's linked to the history of the mother (mother herself might have been abandoned by her parents whom she herself never knew and who would not know her child either). d) Maybe it's linked to a lack of acceptance of the child by a member of the family (example: the new partner of the mother doesn't accept children from a previous relationship) e) Maybe it's an unwanted child f) Perhaps some other fact we are not aware of yet?	We have confirmed a hypothesis, and it is correct. Seen while role-playing	a) Referral to CEFOR b) Restore or develop the mother self-confidence in the mother. Give her importance. c) To see during role-play d) To see during role-play e) To see during role-play f) Continue to find solutions.	Has the mother made the birth certificate?

Remember: The genogram can enable us to make hypotheses regarding difficult relationships, traumatic experiences. But it is important to be cautious when making hypotheses, since sometimes mistakes are made. One must always verify the hypothesis, and abandon it when it appears to be incorrect.

Exercise:

a) Learn why a mother is aggressive toward her son.

Hypothesis: the mother may feel the father left because of the son's birth.

b) Why is the father violent towards his son?

Hypothesis: The father suffered violence from his own father, and is repeating the cycle. And/or maybe the father had no other model to draw from, and he thinks he must beat his child in order to educate him.

c) Understand why Rakoto does not have a birth certificate?

Hypothesis: Maybe he is an unwanted child.

3. How do we use the genogram?

- Make it in the presence of the family whenever possible.
- Draw it over several sessions.
- The genogram is only used in a confidential manner between the family and the social worker.
- The social worker must choose the right moment to suggest creating one (when the family is ready to discuss their family history, when the facilitator is interested in clarifying key family relationships)
- Always begin by representing the person with whom we are doing the genogram, and then the immediate family, and then the extended family.
- Give the genogram to the family if they ask for it (it belongs to the family).
- We use the genogram to learn certain details immediately or much later.

4. Rules regarding the genogram

Always ask the persons if they agree to have a genogram drawn.

If one of the family members does not agree with the making of the genogram against other family members, we must respect their wishes.

5. How do we introduce the genogram to the family?

Bodo role-play.

6. Evaluation

Reading of the genogram.

*Sandrine Charlet, clinical psychologist – ASMAE 2005
English Translation Enfants & Développement 2014,
Edited Anne Carpentier, Gestalt-therapist, Inter Aide Pratiques 22.04.2014*

Asmae 2005 – English translation E&D edited by Pratiques April 2014 - 13